

FHG Cyclopac

for Medium to Heavy Duty Applications

Two Stage Air Cleaners with Safety Element

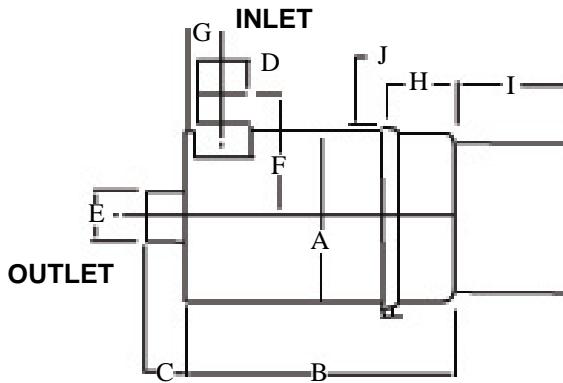
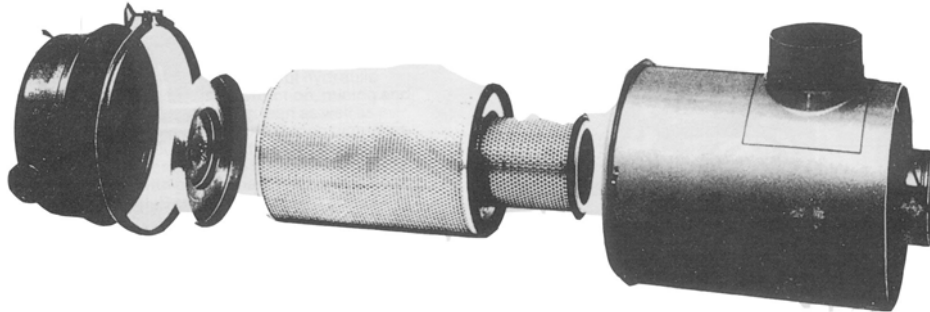

FHG Model Air Cleaners are versatile units and offer maximum reliability when fitted with safety elements. In case of accidental perforation of the primary element or during removal of the primary element the safety element protects the engine.

Engine Air Cleaners

Model No.		CFM Operating Range			Dimensions In Inches											
Without Vac Valve	With Vac Valve	Safety Element Fitted	Initial Restrictions			A	B	C	D	E	F	G	H	I	J	
			6 H2O	8 H2O	10 H2O											
FH G065113	FH G065212	YES	120	140	150	6.55	17.8	2.2	3	3	6.4	1.9	3.2	14.5	7.4	
FH G088013	FH G088010	YES	180	200	220	8	18	2.2	3	3	7	2.6	3.2	14.9	8.9	
FH G100028	FH G100035		345	405	457	10.19	21.1	2.1	4.5	5	8.1	3.4	4	13.1	11.1	
FH G100029	FH G100036	YES	285	333	378	10.19	21.1	2.1	4.5	5	8.1	3.4	4	13.1	11.1	
FH G120012	FH G120037		435	510	565	11.81	18.1	2	5	5	8.9	4.7	4	10.1	13.6	
FH G120014	FH G120036	YES	335	392	442	11.81	18.1	2	5	5	8.9	4.7	4	10.1	13.6	
FH G140023	FH G140055		560	670	750	14	21.1	2.3	6	6	10.1	5.3	4	12.1	15.8	
FH G140022	FH G140054	YES	520	605	680	14	21.1	2.3	6	6	10.1	5.3	4	12.1	15.8	
FH G160057	FH G160049		750	875	990	16	23.1	2.3	7	7	12	5.8	4	14.1	17.8	
FH G160048	FH G160078	YES	620	740	837	16	23.1	2.3	7	7	12	5.8	4	14.1	17.8	

Service Parts

	FHG06	FHG08	FHG10	FHG12	FHG14	FHG16
Primary	P182062	P182059	P182064	P182034	P182046	P182002
Safety Element	P119539	P112212	P119375	P119374	P119373	P119372
Wing Nut	P102144	P102144	P102144	P102144	P102144	P102144
Gasket Washer	P101872	P101872	P101872	P111551	P111551	P111551
Cup Clamp	P002940	P003951	P106071	P100808	P100866	P100789
Cup Gasket	none	none	P101401	P017804	P017335	P017336
Baffle Assembly	P102510	P102980	P103135	P106329	P106771	P106637
Standard Cup	P102805	P103113	P103519	P106589	P106773	P106639
Horizontal Vacuum Cup	P103836	P103837	P103827	P109296	P109297	P106952