

Diesel Pump - P510MAM

FUEL

Specifications:

Height: 12.93" (32.84 cm)
Width: 4.8" (12.19 cm)
Depth: 5.14" (13.05 cm)
Weight (Dry): 7.37 lbs (3.34 kg)
Ports: M16 X 1.5-6H
Service Clearance: 2.5" (6.35 cm)
Max Flow Rate: 72 gph (272 lph)

NOTE: Assembly Includes Control Box, WIF Sensor, and WIF Harness Adapter

Create a Part Number

Mounting Head	12V/24V Pump 72 gph (272 lph)	Filtration Rating	10 micron filtration	Bowl Type	Marine - Metal Bowl
	P5		10		MAM

RACOR®

Dimensions:

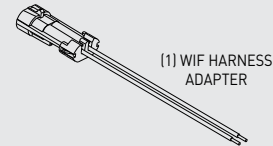
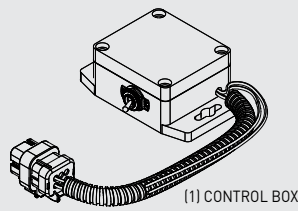
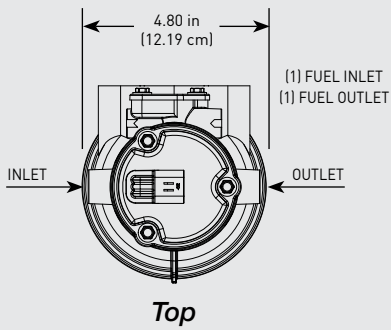

ASSEMBLY	DESCRIPTION
P510MAM	Marine FF/WS, Pump, 72 gph Flow Rate, 10 Micron Filtration

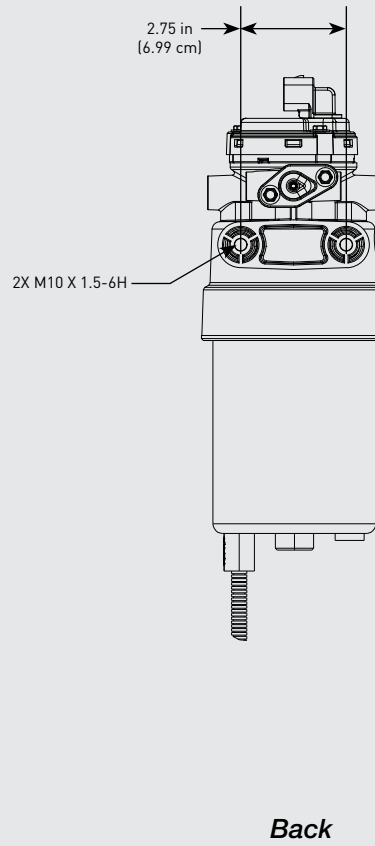
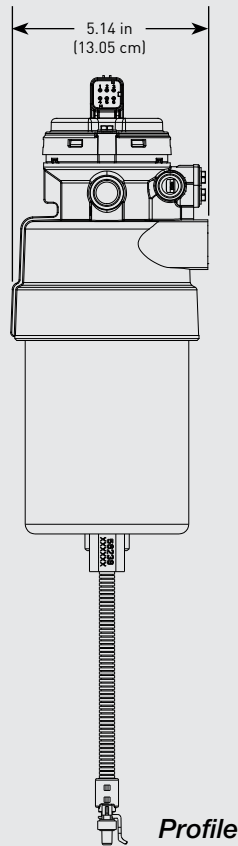
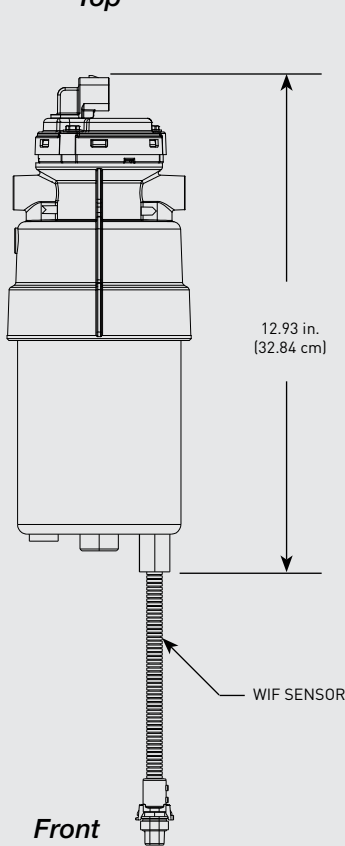

WARNING: The products described in this literature can expose you to chemicals including Diisononyl phthalate, Carbon black extract, which are known to the State of California to cause cancer. For more information go to www.P65Warnings.ca.gov.

PARTS

Diesel Pump - P510MAM

1

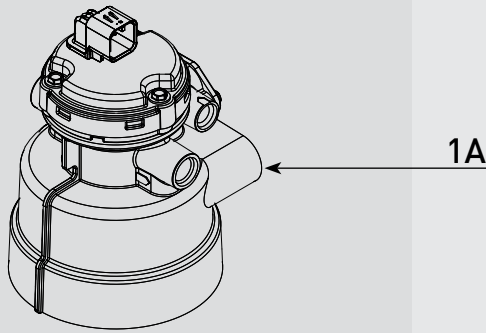

Part #	Description
1A	P510MAM Pump/Head
2A	R58065-2 Replacement Filter - 2 micron - <i>Includes 2B</i> R58065-10 Replacement Filter - 10 micron - <i>Includes 2B</i> R58065-30 Replacement Filter - 30 micron - <i>Includes 2B</i>
2B	Bowl O-ring
3A	P510MAM Housing/Bowl

Additional Parts (not shown)

4A	RK23191	WIF Stainless Steel Probe Kit (1/2"-20 SAE - UL Listed/ABS Marine Type Approved) - No Internal Resistor, 12/24V - <i>Requires Water Detection Amplifier - See RSL7501 for available Probes, Sensors, and Amplifiers</i>
4B	RK 20726	Water Detection Module Kit - 12 or 24 vdc - Includes Amplifier (Light and Buzzer) & RK 21069 (WIF Probe) See RSL7501 for available Probes, Sensors, and Amplifiers
4C	RK45043 RK45044	Fitting Kit (3/8"-18) - <i>Set of two (2) fittings</i> Fitting Kit (1/2"-14) - <i>Set of two (2) fittings</i>

2

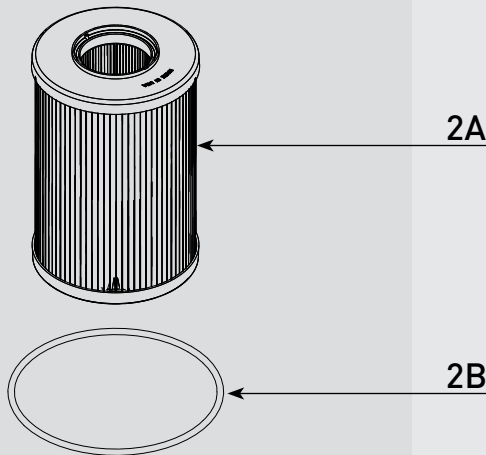

3

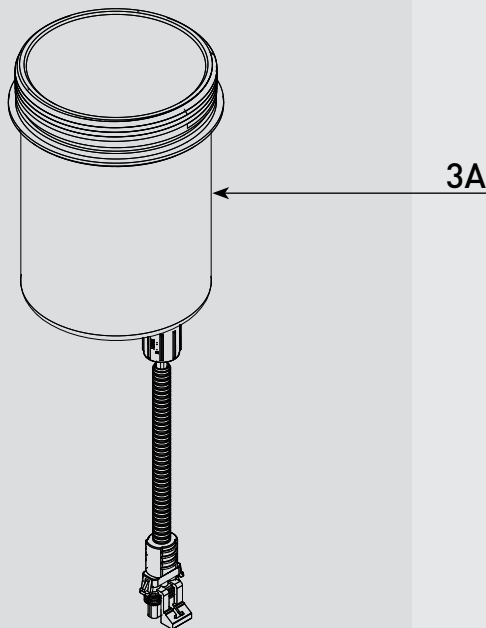

Online Link
P510MAM Product Selector



RSL0381_CUT_Pump_P510MAM (04/18 Rev -)

Questions? Email: racortech@parker.com Phone: 800-344-3286 News: www.racornews.com