

Closed Crankcase Ventilation (CCV)

Installation Instructions for CCV4500, CCV6000, CCV8000, and CCV12000 Series Filters

Instruction Part Number 55021 Rev D



Overview:

Contaminated crankcase emissions are a serious problem for diesel engine owners and the environment. These emissions are a result of gas escaping past piston rings due to high cylinder pressures into the crankcase. In the crankcase, gases are contaminated with oil mist, water, etc. These contaminated emissions escape through the engine breather into the engine compartment and engine intake system.

Racor CCV Systems offer an effective solution to reduce contaminated crankcase emissions. CCV systems remove crankcase emissions, providing protection for the engine and the environment.



Contact Information: Product Features:

Parker Hannifin Corporation
Racor Division
P.O. Box 3208
3400 Finch Road
Modesto, CA 95353

phone 800 344 3286
209 521 7860
fax 209 529 3278
racor@parker.com

www.racorcustomers.com
www.parker.com/racor

- Keeps engine compartments and components clean
- Prevents clogging of engine intakes, turbochargers, and intercoolers
- Improves reliability and maintainability of diesel engines.
- More efficient than other products available on the market
- Reduces environmental pollution from crankcase emissions
- Reduces smoke and odor in the immediate environment



ENGINEERING YOUR SUCCESS.

Table of Contents

Installation Information	3-8
Mounting Details	3
Installation Diagram	4
Installation Guidelines	5
Filter Replacement	5
Hose and Fitting Kits	6
Hose and Fitting Installation	7
Air Intake Connections.....	7
Hose Adapters	8
Hose Barb	8
CCV Conversion Kit.....	8
Heavy-Duty Wear Spacers	9
Electronic Remote Filter Gauge	9
Remote Filter Gauge.....	9
Heater Kits.....	10-11
Specifications	12
Replacement Parts	13-16
CCV4500 Replacement Parts.....	13
CCV6000 Replacement Parts.....	14
CCV8000 Replacement Parts.....	15
CCV12000 Replacement Parts.....	16
Engine Application Guide	17-23
Caterpillar	17-18
Cummins	19
Detroit Diesel	20-21
Hercules	22
Volvo	22
John Deere	23
Mack	23



Mounting Details

CCV Dimensions

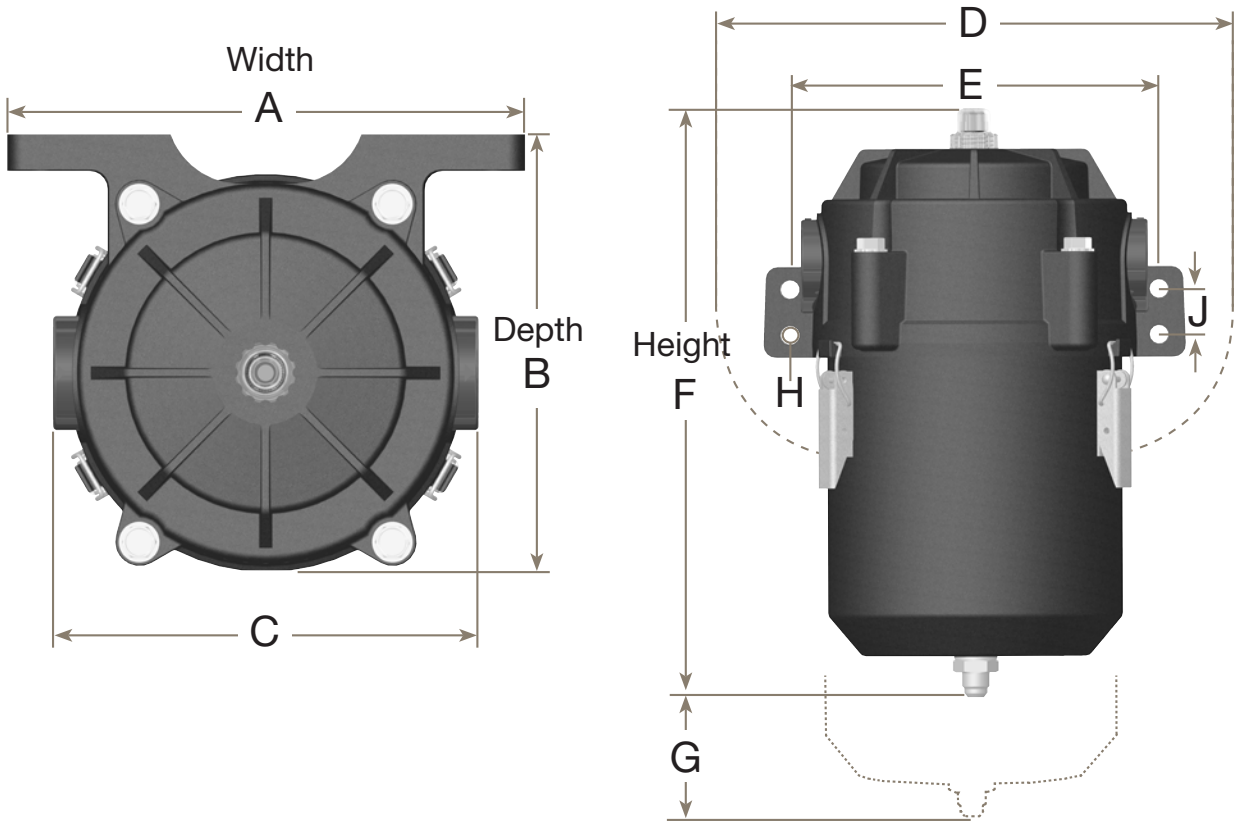

Dimension	4500 Series		6000 Series		8000 Series		12000 Series	
	IN	CM	IN	CM	IN	CM	IN	CM
A	7.2	18.3	8.6	21.8	10.6	26.9	10.6	26.9
B	5.6	14.2	7.3	18.5	9.3	23.6	9.3	23.6
C	5.6	14.2	7.1	18.0	9.1	23.1	9.1	23.1
D	7.5	19.1	11.3	28.7	13.3	33.8	13.3	33.8
E	6.0	15.2	7.5	19.1	9.5	24.1	9.5	24.1
F	9.3	23.6	12.0	30.5	13.9	35.3	18.0	45.7
G¹	2.3	5.8	4.0	10.2	5.0	12.7	6.0	15.2
H	0.43	1.09	0.37	0.94	0.43	1.09	0.43	1.09
J²	N/A	N/A	0.93	2.4	1.06	2.7	1.06	2.7

¹ Dimension "G" is the minimum filter removal clearance - allow more room if possible for ease of service.

² Dimension "J" is not applicable on CCV4500 assemblies because there are only two (2) mounting holes. All other units have four (4) mounting holes.

Installation Diagram

Industrial/Mobile Power Applications

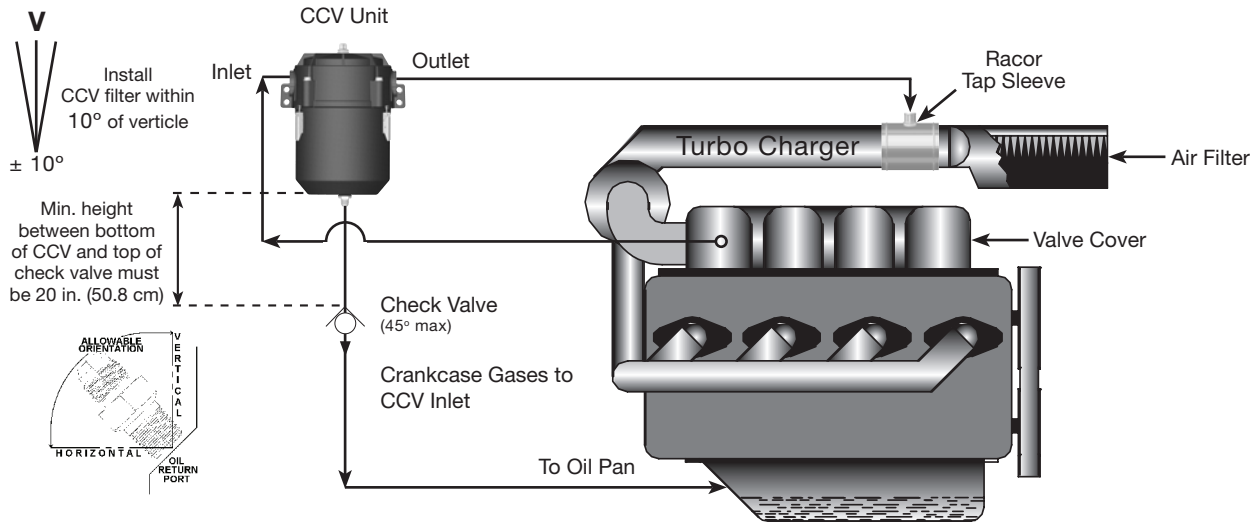

Marine Applications

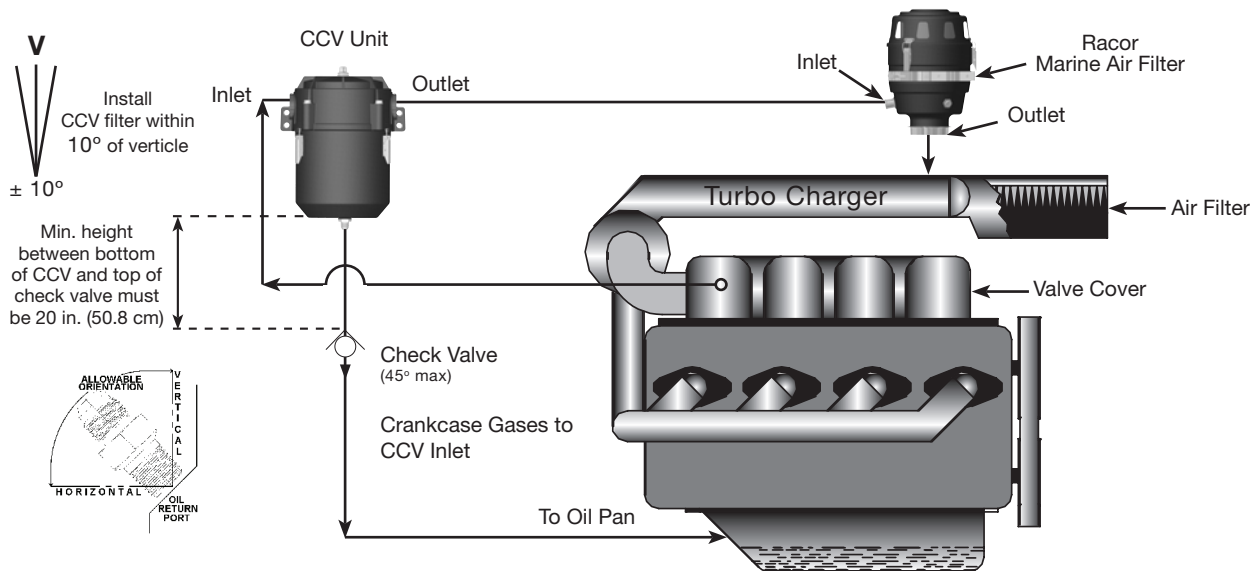

Installation Guidelines

- CCV is available as left-hand or right-hand inlet to facilitate plumbing.
- CCV must be mounted upright ($\pm 10^\circ$) and may be engine mounted or remote mounted.
- Ensure enough clearance underneath for servicing filter. Minimum clearance is:
CCV4500 - 2.25"
CCV6000 - 4.00"
CCV8000 - 5.00"
CCV12000 - 11.00"
- Avoid mounting locations in areas of extreme temperatures (exhaust manifold).
- Avoid low spots or valleys in hoses to prevent restriction. Keep hoses clear of hot spots.
- CCV must be mounted level with or higher than engine. This allows oil to flow to oil pan.
- Locate an unused dipstick boss or other access to crankcase. Install drain check valve as low as possible into crankcase, preferably above oil level. *Note: Check valve must be oriented between vertical and horizontal ($\pm 45^\circ$).*

CAUTION: Drilling into block or oil pan is not recommended. Consult with engine manufacturer for proper hookup of drain valve.

a marine air filter; vertical distance (in inches) from assembly sump drain fitting to drain check valve must be equal to or greater than the max. marine air filter inlet restriction (in inches of water). If not, then accumulated oil in sump will not return to oil pan properly.

Example: Air filter inlet restriction is 6.0 in inches water. Vertical distance from sump drain fitting to drain check valve should be min. of 6.0 in.

- **INTERMITTENT DUTY APPLICATIONS** - The sump capacity will allow for 24 hours of operation and will drain at idle or shutdown.

Filter Replacement

The only routine maintenance for the CCV system is replacement of the filter media. Typical service life of filters for diesel application is 750 hours. Some variations in this occur, depending on load profile, engine wear condition, flow and aerosol mass concentration of crankcase emissions, soot concentration, etc.

The CCV is equipped with the red filter service indicator. If the filter becomes plugged prior to normal service interval, increased pressure against regulator valve lifts the diaphragm, causing the filter service indicator to appear. Indicating the need to change the filter. Change the filter and re-set the indicator by unscrewing the clear plastic cover and pushing indicator button down. Replace cover.

CAUTION: Shut down engine before servicing. If not possible, avoid moving parts, engine hot spots, and electrical connections. Wear safety glasses and hearing protectors. Note: vacuum in filter canister during engine operation may make it difficult to separate.

- Release latches which hold canister to filter head assembly.
- Drop canister down to expose filter. *Note: A light amount of oil may be seen in bottom. Use caution to avoid spillage.*
- Remove filter by pulling down, dispose properly, according to local regulations. Be sure o-ring on top of filter cap and o-ring on bottom of head assembly are removed.
- Install new o-ring on bottom of head assembly.

- Be sure new o-ring is on top of new filter cap; push filter up in place, locating top end cap into hole in bottom center of head assembly.
- Replace canister. Align latches in canister with catches on filter head assembly. Clamp and snap latches closed. Servicing is complete.
- Visually check system for signs of excessive rubbing or any leaks. Correct as necessary.



Hose and Fitting Kits

SELECT A FITTING/HOSE KIT:
Fitting/Hose Kits come with both fittings and enough hose for inlet and outlet sides of the Racor CCV assembly. Racor CCV assemblies

require fittings available only from Racor. In order to determine the correct application, you need to know the quantity and the outside diameter of engine breather(s)/

hose connection. Fitting/Hose Kits are available in various sizes and configurations.

CCV4500 Series Assemblies

Part No.	Description
CCV55024	(1) 3/4" fitting, (1) 1" fitting, (1) 3/4" ID x 4 foot long hose, (1) 1" ID x 4 foot long hose, (4) clamps and (4) ties
CCV55025	(2) 1" fittings, (1) 1" ID x 8 foot long hose, (4) clamps and (4) ties
CCV55037	(1) 1-1/4" fitting, (1) 1" fitting, (1) 1-1/4" ID x 4 foot long hose, (1) 1" ID x 4 foot long hose, (4) clamps and (4) ties
CCV55038	(1) 3/4" fitting, (1) 1" fitting, (1) 3/4" ID x 6 foot long hose, (1) 3/4" Tee fitting, (1) 1" ID x 4 foot long hose, (8) clamps and (8) ties

CCV6000 Series Assemblies

Part No.	Description
CCV55046	(2) 1-1/4" fittings, (1) 1-1/4" ID x 8 foot long hose, (4) clamps and (4) ties
CCV55047	(2) 1-1/4" fittings, (1) 1-1/4" Tee fitting, (1) 1-1/4" ID x 10 foot long hose, (8) clamps and (8) ties
CCV55048	(2) 1-1/4" fittings, (1) 1-1/2" ID x 4 foot long hose, (1) bushing reducer, (1) 1-1/4" ID x 4 foot long hose, (4) clamps and (4) ties
CCV55049	(2) 1-1/4" fittings, (1) 1-1/2" ID x 5 foot long hose w/2" cuff, (1) bushing reducer, (1) 1-1/4" ID x 4 foot long hose, (4) clamps and (4) ties

CCV8000 and CV12000 Series Assemblies

Part No.	Description
CCV55067	(2) 1-1/2" fittings, (1) 1-1/2" ID x 10 foot long hose, (1) bushing reducer, (4) clamps and (4) ties
CCV55068	(2) 1-1/2" fittings, (1) 1-1/2" Tee fitting, (1) 1-1/2" ID x 12 foot long hose, (2) bushing reducers, (8) clamps and (8) ties
CCV55069	(2) 1-1/2" fittings, (1) 1-1/2" ID x 5 foot long hose w/2" cuff, (1) bushing reducer, (1) 1-1/2" ID x 5 foot long hose, (4) clamps and (4) ties

Hump Hose Fitting Kits

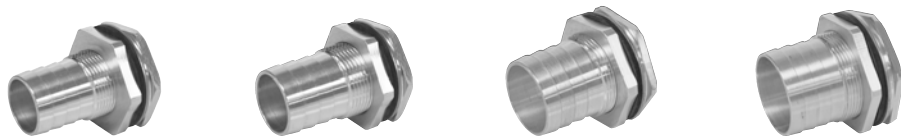

	CCV55540	CCV55113	CCV55114	CCV55115
Hose Diameter	3/4"	1"	1 1/4"	1 1/2"

Hose and Fitting Installation

Determine flow direction of CCV Assembly.

1. Install fitting into outlet port, torque to 50 in. lbs.
2. Install remaining fitting into inlet port, torque to 50 in. lbs.
3. Select appropriate hose from kit and secure to CCV inlet fitting with clamp provided.
4. Locate engine breather connection and cut inlet hose to required length.

CAUTION! When cutting hose, exercise extreme caution. Hose is wire reinforced and protruding sharp edge can result in bodily injury!

5. Secure hose to engine breather connection with clamp provided. *Note: If engine breather connection is smaller than hose ID, use appropriate size rubber bushing on breather.*
6. Select appropriate hose from kit and secure to CCV outlet fitting with clamp provided.
7. Locate air intake connector fitting barb and cut hose to required length.
8. Secure hose to air intake connector barb with clamp provided.
9. Secure hose(s) to convenient location, away from engine hot

spots, with ties provided. *Note: Avoid low spots or valleys in hoses to prevent flow restriction.*

Attaching Multiple Breathers -

- a. Use tee fitting provided to branch to both breathers.
- b. Extra hose has been provided to accommodate installation of multiple breathers.
- c. Verify inlet and outlet distance before cutting any hose.

Air Intake Connectors

Tap Sleeve - for Industrial/Mobile Power Applications: Tap sleeves provide for connection of Racor CCV outlet to engine's air intake. Determine inside diameter of hose between turbocharger and air filter. This will determine outside diameter of tap sleeve required for installation.



Part No.	Size
CCV30100	3" x 1"
CCV40100	4" x 1"
CCV50125	5" x 1-1/4"
CCV60125	6" x 1-1/4"

Marine Air Filter Assembly

To determine correct marine air filter application, marine air filter rating (AFR) is required. Choose correct marine air filter application per guideline:

4 cycle engines AFR = HP x 2.0
2 cycle engines AFR = HP x 2.5

Examples:

2 cycle - twin turbo
826 HP x 2.5 = 1032.5 AFR per turbo; select (2) AFM501012

4 cycle - single turbo
660 HP x 2.0 = 1320.0 AFR; select (1) AFM601212

Note: Customer provides hose connection to turbocharger.

Max Flow Rate	
Marine Air Filter	AFR
AFM408512	800 CFM
AFM501012	1200 CFM
AFM601212	1600 CFM



Marine Air Filter	Replacement Filter Part No.	Outlet Dia.	Length	Hose Barb	Dia.
AF M408512	AF M8040	4"	12"	1"	8.5"
AF M501012	AF M8050	5"	12"	1"	10"
AF M601212	AF M8060	6"	12"	1.25"	12"

Note: AF M601212 includes 1-1/4" x 1-1/2" Bushing (connects to 1-1/2" I.D. Hose)

90° Hose Adapters



Part No.	CCV55547-02
Use with Model	CV4500
1 3/16"-12 UN	



Part No.	CCV55121
Use with Model	CV6000
1 5/8"-12 x 1 1/4" H.B.	



Part No.	CCV55547-10
Use with Model	CV8000
1 7/8"-12 UN	

Accessories

Hose Barbs

CV Assembly	Hose Barb Part No.	Size
CCV4500	CCV55251	0.75"
CCV4500	CCV55250	1"
CCV4500	CCV55280	1.25"
CCV6000	CCV55089	0.75"
CCV6000	CCV55268	1.25"
CCV6000	CCV55121	1.25" (90°)
CCV6000	CCV55267	1.5"
CCV8000/CCV12001	CCV55218	1.5"



CCV Conversion Kit

Part Number:

CCV55613-08
(High Density)

CCV55613-10
(Ultra Density)

The CCV55613-08 and CCV55613-10 allow the CCV8001 to be converted to a CCV12001. The CCV12001 series offers 60%

additional media. The CCV12001 series is great for applications where extra capacity is desired and immediate engine accessibility is not available. It allows for increased efficiency and longer service intervals. Kit includes element, wear spacer, o-rings, and CCV12001 bowl.



Heavy-Duty Wear Spacers

These Heavy-Duty Spacers are an optional accessory for engine applications/ installations that have excessive vibration. Excessive vibration causes abnormal wear on the CCV assembly and could compromise integrity. The spacer is placed in the CCV canister, below the filter,

protecting the assembly from vibration and wear by cradling the filter.

CCV Unit	Spacer No.
CCV4500	CCV55390
CCV6000	CCV55385
CCV8000	CCV55374
CCV12000	CCV55374



Electronic Remote Filter Gauge

The CCV55615-01 Lightbox Kit is designed to inform the user that the filter being monitored has become restricted.

During normal vehicle operation, the green light stays illuminated indicating the filter is performing properly. The red light illuminates when the filter becomes restricted and stays on until the engine is shut down. The light box is reset when the engine is shut down and the red light will not illuminate until filter restriction is again seen in the system.

- **Constant monitoring of filter condition while engine is on**
- **12Vdc operating supply voltage**
- **Operating temperature: -40°F to +257°F (-40°C to +125°C)**
- **5 amp max current draw**
- **Filter switch threads are 3/8"-24 straight thread**
- **Rugged construction**
- **Filter switch closure at 8 inches of water**

- **Green and red light illumination to show filter condition**



Remote Filter Gauge

Part Number:
CCV55012

This Vacuum Indicator was designed to inform the user that the filter being monitored has become restricted.

Included in Kit:

Gauge and Bracket (shown),
1/8"-27 NPT fitting, 40 micron filter,
and 10 foot of 1/4" OD EPDM hose.



Heater Kits

Closed Crankcase Ventilation (CCV) Systems are used to prevent emissions from contaminating internal surfaces of the engine air induction system and prevent engine room environments from being coated with oily residue. Both functions maintain engine performance and improve operating environment over the life of the engine. In cold weather applications, gases and vapors processed by the CCV system are affected by ambient conditions. The canister is cooled to ambient temperature and oil mist and water vapor particles traveling through the CCV system will then coalesce against the cold interior surfaces of the CCV

canister. This process introduces microscopic particles of oil and water to each other. When they mix, an emulsification of the two liquids occurs. This emulsification turns the two particles into a creamy jelly-like substance. The mixture slowly builds up as cold air continually cools the canister and the process repeats itself. The emulsified oil-water mixture collect to a point where element life is compromised and crankcase pressure will rise. These heater kits prevent this build-up and ensure filter life by warming the canister surfaces. The temperature of the canister is raised near to that of the crankcase gases entering the

CCV assembly. If the canister surfaces are as warm as the crankcase gases, then the oil and water mixture will not coalesce on the interior walls. Since no oil or water coalesces, no emulsification occurs.



Installation Diagram

CCV4500
CCV6000
CCV8000
CCV12000

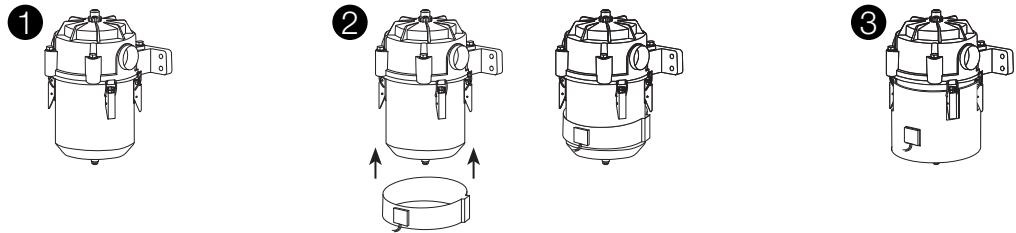

Installation Guidelines

1. Clean exterior of CCV canister thoroughly. Adhesive is used to bond insulating sleeve to canister. Oily film present on canister surfaces will affect adhesion.
2. Wrap heater band around CCV assembly and secure Velcro closure to fasten to canister. Align plug with center of CCV product label.
3. Slide insulation sleeve over heater band. Secure sleeve to CCV assembly with adhesive strips located on top of sleeve.
4. For AC models - Connect power cord to appropriate power source with 15 amp circuit.
5. For DC models - See Wiring Diagram on next page for proper installation.
6. Allow enough slack in power cord for element removal (servicing). When routing power cord, avoid rubbing areas and hot surfaces.

Note: These heaters are thermostatically controlled and

will turn ON when the canister falls below 156°F (69°C) and will turn OFF when the canister reaches 174°F (79°C). It will take approximately 4 minutes for heater to warm CCV canister to maximum temperature.

Wiring Diagram

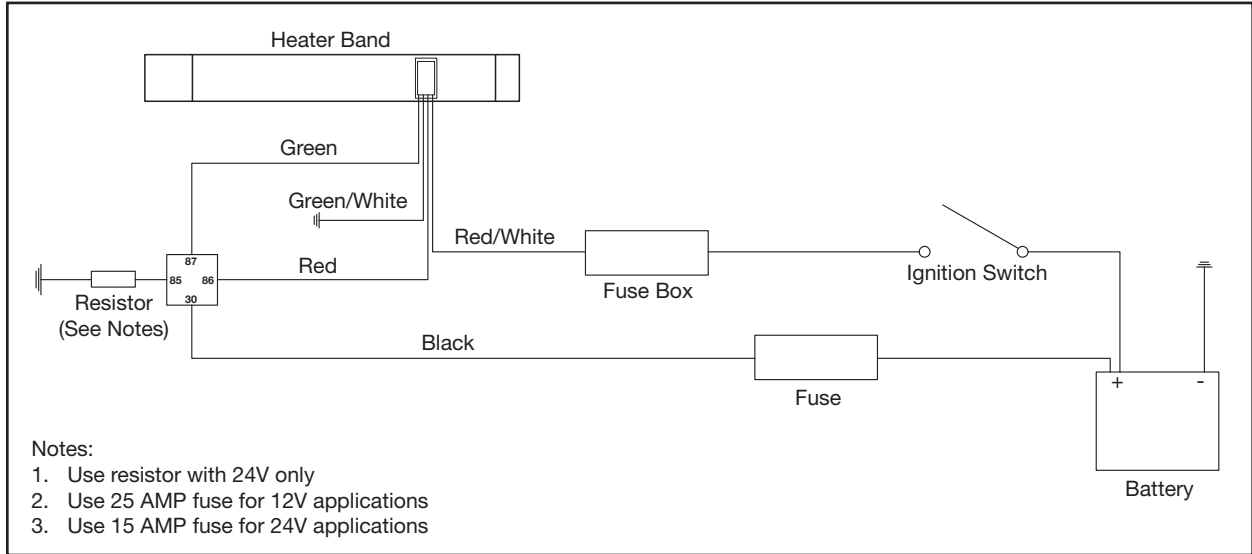

Replacement Kits

CCV Assembly	120V AC Heater Kit	12V DC Heater Kit	24V DC Heater Kit	Wattage
CCV4500	CCV55461	CCV55461-12	CCV55461-24	100
CCV6000	CCV55462	CCV55462-12	CCV55462-24	150
CCV8000	CCV55463	CCV55463-12	CCV55463-24	200
CCV12000	CCV55642	CCV55642-12	CCV55642-24	200

Note: Kits include heater band and insulation sleeve only. CCV assembly sold separately.



CCV Specifications



	CCV4500	CCV6000	CCV8000	CCV12000
Max. Flow Rate	10 CFM (283 LM)	20 CFM (566 LM)	40 CFM (1133 LM)	50 CFM (1416 LM)
Max. Engine Rating	400 HP (298 KW)	800 HP (597 KW)	1600 HP (1193 KW)	2000 HP (1491 KW)
Inlet/Outlet Port Size	1 3/16"-12 SAE	1 5/8"-12 SAE	1 7/8"-12 SAE	1 7/8"-12 SAE
Weight	3.3 lbs (1.5 kg)	5.0 lbs (2.3 kg)	8.7 lbs (3.9 kg)	9.3 lbs (4.2 kg)
Low Density Filter Replacement	CCV55248-04	N/A	N/A	N/A
High Density Filter Replacement	CCV55248-08	CCV55274-08	CCV55222-08	CCV55222-12-08
Ultra Density Filter Replacement	CCV55248-10	CCV55274-10	CCV55222-10	CCV55222-12-10
Housing Material	Die cast head, glass-filled nylon and black powder epoxy-coated steel bowl.	Die cast head, glass-filled nylon and black powder epoxy-coated steel bowl.	Die cast head, glass-filled nylon and black powder epoxy-coated steel bowl.	Die cast head, glass-filled nylon and black powder epoxy-coated steel bowl.
Crankcase Pressure Regulator	Integral	Integral	Integral	Integral
Bypass/Change Indicator	Integral or Remote	Integral or Remote	Integral or Remote	Integral or Remote
Engine BlockCheck Valve Return Fitting	1/4" NPT	1/4" NPT	3/8" NPT	3/8" NPT
Swivel Fitting (Qty.)	#6 JIC (2 pcs.)	#6 JIC (2 pcs.)	#8 JIC (2 pcs.)	#8 JIC (2 pcs.)
Oil Drain Hose I.D.	0.375 in. (0.95 cm)	0.375 in. (0.95 cm)	0.5 in. (1.27 cm)	0.5 in. (1.27 cm)

Units can be manifolded to handle higher flow rates.



CCV4500 Replacement Parts

Part No.	Description
1. CCV55081	Bypass Indicator Kit
2. CCV55246L	Head Assembly (Left Side Inlet)
CCV55246R	Head Assembly (Right Side Inlet)
3. CCV55247	Diaphragm Kit
4. CCV55248-08	Filter Replacement - High Density
CCV55248-10	Filter Replacement - Ultra Density
5. CCV55249	Can Assembly
6. CCV55279	1/4" MNPT Drain/Check Valve Kit

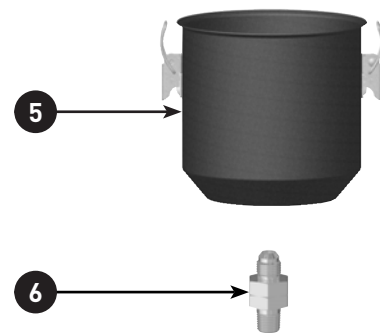
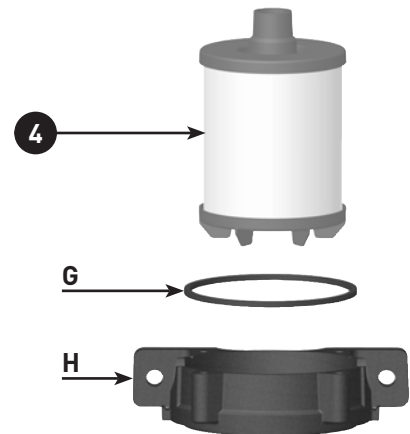
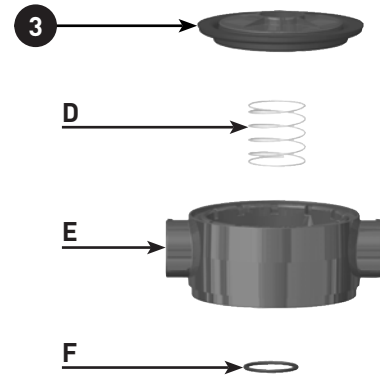
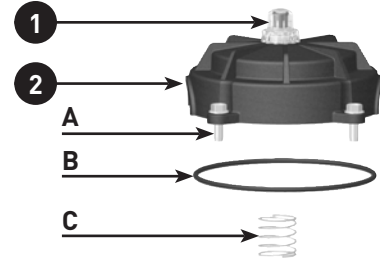

Hose and Fitting Kits

Part No.	Description
CCV55024	(1) 3/4" fitting, (1) 1" fitting, (1) 3/4" ID x 4' hose, (1) 1" ID x 4' hose, (4) clamps, (4) ties
CCV55025	(2) 1" fittings, (1) 1" ID x 8' hose, (4) clamps, (4) ties
CCV55037	(1) 1 1/4" fitting, (1) 1" fitting, (1) 1 1/4" ID x 4' hose, (1) 1" ID x 4' hose, (4) clamps, (4) ties
CCV55038	(1) 3/4" fitting, (1) 1" fitting, (1) 3/4" ID x 6' hose, (1) 3/4" Tee fitting, (1) 1" ID x 4' hose, (8) clamps, (8) ties

Inlet/Outlet Fitting Kits

Part No.	Description
CCV55250	1" OD Hose Barb to 1 3/16" SAE fitting
CCV55251	3/4" OD Hose Barb to 1 3/16" SAE fitting
CCV55280	1 1/4" OD Hose Barb to 1 3/16" SAE fitting

CCV6000 Replacement Parts

Part No.	Description
1. CCV55081	Bypass Indicator Kit
2. CCV55272L	Head Assembly (Left Side Inlet) <i>(Kit includes 1, 3, A, B, C, D, E, and H)</i>
CCV55272R	Head Assembly (Right Side Inlet) <i>(Kit includes 1, 3, A, B, C, D, E, and H)</i>
3. CCV55273	Diaphragm Kit
4. CCV55274-08	Filter Replacement - High Density <i>(Kit includes F and G)</i>
CCV55274-10	Filter Replacement - Ultra Density <i>(Kit includes F and G)</i>
5. CCV55275	Can Assembly <i>(Kit includes G)</i>
6. CCV55279	1/4" MNPT Drain/Check Valve Kit

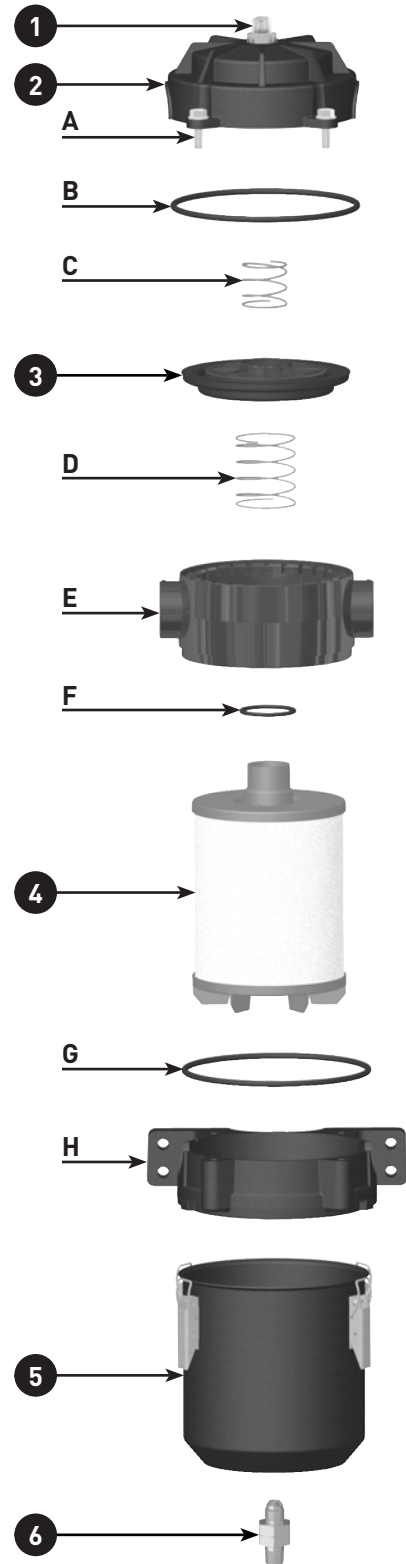

Hose and Fitting Kits

Part No.	Description
CCV55046	(2) 1 1/4" fitting, (1) 1 1/4" ID x 8' hose, (4) clamps, (4) ties
CCV55047	(2) 1 1/4" fitting, (1) 1 1/4" Tee fitting, 1 1/4" ID x 10' hose, (8) clamps, (8) ties
CCV55048	(2) 1 1/4" fitting, (1) 1 1/2" ID x 4' hose, (1) bushing reducer, (1) 1 1/4" ID x 4' hose, (4) clamps, (4) ties
CCV55049	(2) 1 1/4" fitting, (1) 1 1/2" ID x 5' hose w/2" cuff, (1) bushing reducer, (1) 1 1/4" ID x 4' hose, (4) clamps, (4) ties

Inlet/Outlet Fitting Kit

Part No.	Description
CCV55267	1 1/2" OD Hose Barb to 1 5/8" SAE fitting

CCV8000 Replacement Parts

Part No.	Description
1. CCV55081	Bypass Indicator Kit
2. CCV55220L	Head Assembly (Left Side Inlet)
CCV55220R	Head Assembly (Right Side Inlet)
3. CCV55221	Diaphragm Kit
4. CCV55222-08	Filter Replacement - High Density
CCV55222-08	Filter Replacement - Ultra Density
5. CCV55223	Can Assembly
6. CCV55080	3/8" MNPT Drain/Check Valve Kit

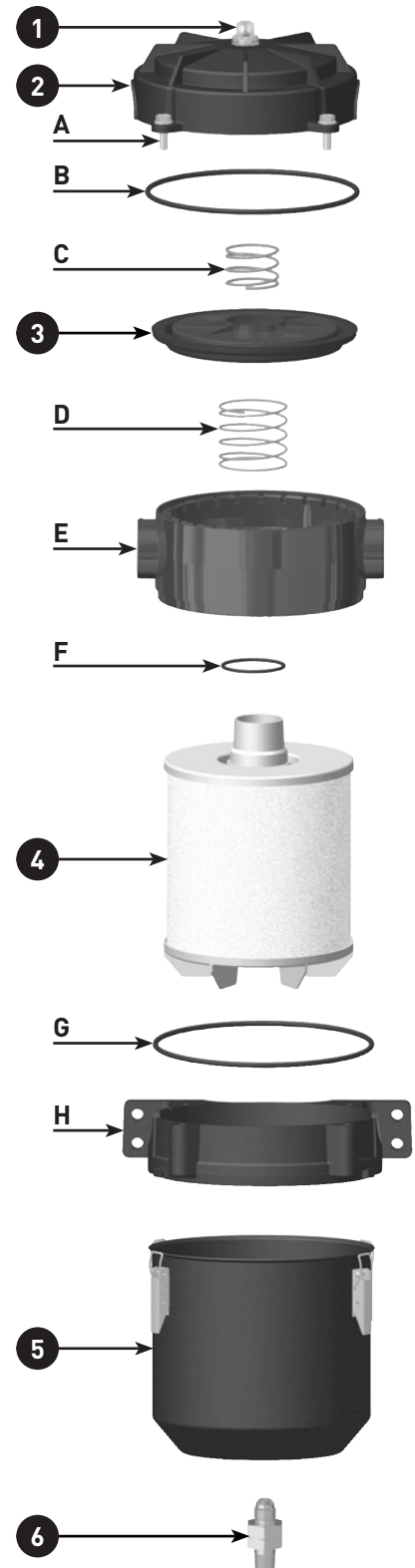

Hose and Fitting Kits

Part No.	Description
CCV55067	(2) 1 1/2" fittings, (1) 1 1/2" ID x 10' hose, (1) bushing reducer, (4) clamps, (4) ties
CCV55068	(2) 1 1/2" fittings, (1) 1 1/2" Tee fitting, 1 1/2" ID x 12' hose, (2) bushing reducers, (8) clamps, (8) ties
CCV55069	(2) 1 1/2" fittings, (1) 1 1/2" ID x 5' hose w/2" cuff, (1) bushing reducer, (1) 1 1/2" ID x 5' hose, (4) clamps, (4) ties

Inlet/Outlet Fitting Kit

Part No.	Description
CCV55218	1 1/2" OD Hose Barb to 1 7/8" SAE fitting

CCV12000 Replacement Parts

Part No.	Description
1. CCV55081	Bypass Indicator Kit
2. CCV55200L CCV55200R	Head Assembly (Left Side Inlet) <i>(Kit includes 1, 3, A, B, C, D, E, and H)</i> Head Assembly (Right Side Inlet) <i>(Kit includes 1, 3, A, B, C, D, E, and H)</i>
3. CCV55221	Diaphragm Kit
4. CCV55222-12 CCV55222-12-10	Filter Replacement - High Density <i>(Kit includes F and G)</i> Filter Replacement - Ultra Density <i>(Kit includes F and G)</i>
5. CCV55570	Can Assembly <i>(Kit includes G)</i>
6. CCV55080	3/8" MNPT Drain/Check Valve Kit

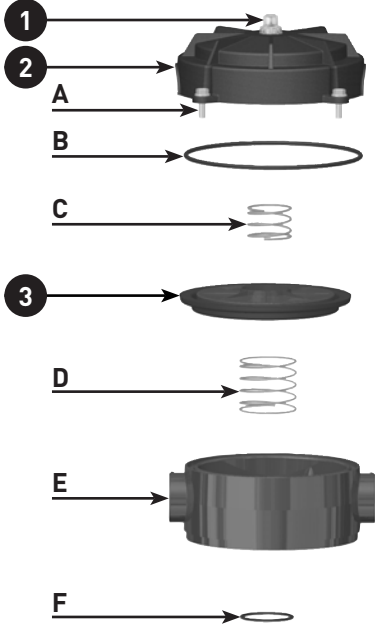

Hose and Fitting Kits

Part No.	Description
CCV55067	(2) 1 1/2" fittings, (1) 1 1/2" ID x 10' hose, (1) bushing reducer, (4) clamps, (4) ties
CCV55068	(2) 1 1/2" fittings, (1) 1 1/2" Tee fitting, 1 1/2" ID x 12' hose, (2) bushing reducers, (8) clamps, (8) ties
CCV55069	(2) 1 1/2" fittings, (1) 1 1/2" ID x 5' hose w/2" cuff, (1) bushing reducer, (1) 1 1/2" ID x 5' hose, (4) clamps, (4) ties

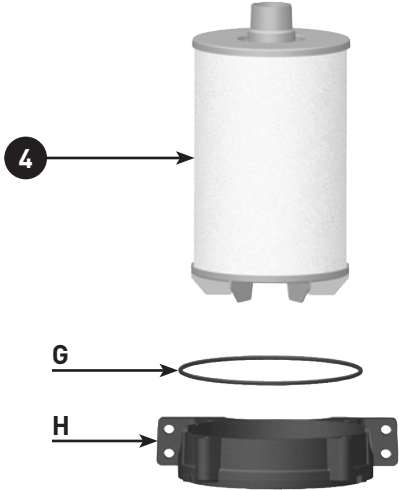

Inlet/Outlet Fitting Kit

Part No.	Description
CCV55218	1 1/2" OD Hose Barb to 1 7/8" SAE fitting

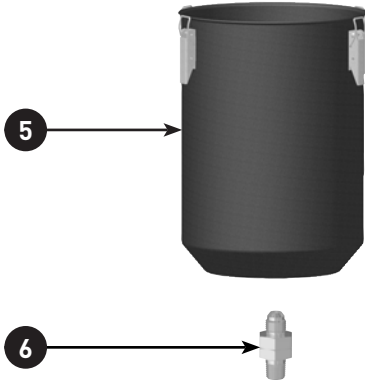

CCV Engine Applications

Caterpillar - Industrial/Mobile Power Applications

ENGINE MODEL NO.	QTY.	P/N	DESCRIPTION
3208 (2 breathers)	1	CCV4500-08L (or R)	Filter Unit
	1	CCV55038	Fitting/Hose Kit
	1	CCV40100	Tap Sleeve
3054, 3056 <i>Verify breather outlet and turbo inlet outside diameter sizes</i>	1	CCV4500-08L (or R)	Filter Unit
	1	CCV55024	Fitting/Hose Kit
	1	AF M408512	Marine Air Filter
3116, 3304, 3306, 3126	1	CCV4500-08L (or R)	Filter Unit
	1	CCV55037	Fitting/Hose Kit
	1	CCV40100	Tap Sleeve
3406, D343	1	CCV6000-08L (or R)	Filter Unit
	1	CCV55046	Fitting/Hose Kit
	1	CCV60125	Tap Sleeve
3408, 3176	1	CCV6000-08L (or R)	Filter Unit
	1	CCV55047	Fitting/Hose Kit
	1	CCV60125	Tap Sleeve
3412 (2 breathers)	1	CCV6000-08L	Filter Unit
	1	CCV6000-08R	Filter Unit
	2	CCV55046	Fitting/Hose Kit
3412 (High Output, 4 breathers) <i>Customer to provide connection to air intake</i>	1	CCV6000-08L	Filter Unit
	1	CCV6000-08R	Filter Unit
	2	CCV55047	Fitting/Hose Kit
3508 - Single Turbo <i>Customer to provide connection to air intake</i>	1	CCV8000-08L (or R)	Filter Unit
	1	CCV55069	Fitting/Hose Kit
3508 - Twin Turbo: D379, D398, D399 <i>Customer to provide connection to air intake</i>	1	CCV6000-08L	Filter Unit
	1	CCV6000-08R	Filter Unit
	2	CCV55049	Fitting/Hose Kit
3512, 3516, D398, D399 <i>Customer to provide connection to air intake</i>	1	CCV8000-08L	Filter Unit
	1	CCV8000-08R	Filter Unit
	2	CCV55069	Fitting/Hose Kit
3606 <i>Customer to provide connection to air intake</i>	3	CCV8000-08L (or R)	Filter Unit
	3	CCV55069	Fitting/Hose Kit
3612, 3616 <i>Customer to provide connection to air intake</i>	2	CCV8000-08L	Filter Unit
	2	CCV8000-08R	Filter Unit
	4	CCV55069	Fitting/Hose Kit

Note: Most engines come with elephant-ear air cleaners. Air intake configurations vary considerably and customer should verify outside diameter size of turbo inlet and ability to use tap sleeves or marine air filters. If not, customer can weld a fitting to the clean side of filter element on the back of the housing. Always verify outside diameter size of breathers for hose applications.

CCV Engine Applications

Caterpillar - Marine Applications

ENGINE MODEL NO.	QTY.	P/N	DESCRIPTION
3208 (2 breathers)	1	CCV4500-08L (or R)	Filter Unit
	1	CCV55038	Fitting/Hose Kit
	1	AF M408512	Marine Air Filter
3208 (High Output) <i>Connect to CAT fitting on air intake</i>	1	CCV6000-08L (or R)	Filter Unit
	1	CCV55049	Fitting/Hose Kit
3054, 3056 <i>Verify breather outlet and turbo inlet outside diameter sizes</i>	1	CCV4500-08L (or R)	Filter Unit
	1	CCV55024	Fitting/Hose Kit
	1	AF M408512	Marine Air Filter
3116, 3304, 3306, 3126	1	CCV4500-08L (or R)	Filter Unit
	1	CCV55037	Fitting/Hose Kit
	1	AF M408512	Marine Air Filter
3406, D343, 3176, 3196	1	CCV6000-08L (or R)	Filter Unit
	1	CCV55046	Fitting/Hose Kit
	1	AF M601212	Marine Air Filter
3408 - Single Turbo	1	CCV6000-08L (or R)	Filter Unit
	1	CCV55047	Fitting/Hose Kit
	1	AF M601212	Marine Air Filter
3408 - Twin Turbo, 3412 (2 breathers)	1	CCV6000-08L	Filter Unit
	1	CCV6000-08R	Filter Unit
	2	CCV55046	Fitting/Hose Kit
	2	AF M501212	Marine Air Filter
3412 (High Output, 4 Breathers)	1	CCV6000-08L	Filter Unit
	1	CCV6000-08R	Filter Unit
	2	CCV55047	Fitting/Hose Kit
	2	AF M501212	Marine Air Filter
3508, D379, D398, D399 <i>Customer to provide connection to air intake</i>	1	CCV6000-08L	Filter Unit
	1	CCV6000-08R	Filter Unit
	2	CCV55049	Fitting/Hose Kit
3512, 3516, 3606, D398, D399 <i>Customer to provide connection to air intake</i>	1	CCV8000-08L	Filter Unit
	1	CCV8000-08R	Filter Unit
	2	CCV55069	Fitting/Hose Kit
3606 <i>Customer to provide connection to air intake</i>	3	CCV8000-08L (or R)	Filter Unit
	3	CCV55069	Fitting/Hose Kit
3612, 3616 <i>Customer to provide connection to air intake</i>	2	CCV8000-08L	Filter Unit
	2	CCV8000-08R	Filter Unit
	4	CCV55069	Fitting/Hose Kit

Cummins - Industrial/Mobile Power Applications

ENGINE MODEL NO.	QTY.	P/N	DESCRIPTION
3A1.7, 4A2.1, 4B3.9, 4BT3.9, 6B5.9, 6BT5.9, 6BTA5.9, 6C8.3, 6CT8.3, 6CTA8.3, L10, V504, VT504, VT555, VTA555	1	CCV4500-08L	Filter Unit
	1	CCV55024	Fitting/Hose Kit
	1	CCV30100 (3") or CCV40100 (4")	Tap Sleeve (Turbo)
KT19, KTA19, M11, N14	1	CCV6000-08L	Filter Unit
	1	CCV55046	Fitting/Hose Kit
	1	CCV50125	Tap Sleeve
V-903, VT-903, NTA-855, VTA-903	1	CCV6000-08L	Filter Unit
	1	CCV55047	Fitting/Hose Kit
	1	CCV50125	Tap Sleeve
VTA28, KTA38, KTA50, KTTA50	1	CCV6000-08L	Filter Unit
	1	CCV6000-08R	Filter Unit
	1	CCV55046	Fitting/Hose Kit
	1	CCV60125	Tap Sleeve

Note: Most engines, customer provides bushings for hose kit installation to engine breathers.
New 3/4" breather barb available from Cummins.

Cummins - Marine Applications

ENGINE MODEL NO.	QTY.	P/N	DESCRIPTION
3A1.7, 4A2.1, 4B3.9, 4BT3.9, 6B5.9, 6BT5.9, 6BTA5.9, 6C8.3, 6CT8.3, 6CTA8.3, V504, VT504, VT555, VTA555	1	CCV4500-08L	Filter Unit
	1	CCV55024	Fitting/Hose Kit
	1	AF M408512	Marine Air Filter
KT19, KTA19, M11, N14	1	CCV6000-08L	Filter Unit
	1	CCV55046	Fitting/Hose Kit
	1	AF M601212	Marine Air Filter
V-903, VT-903, NTA-855, VTA-903	1	CCV6000-08L	Filter Unit
	1	CCV55047	Fitting/Hose Kit
	1	AF M501012	Marine Air Filter
VTA28, KTA38,	1	CCV6000-08L	Filter Unit
	1	CCV6000-08R	Filter Unit
	1	CCV55046	Fitting/Hose Kit
	1	AF M501012	Marine Air Filter
KTA50, KTTA50 (Emergency/Intermittent Duty)	1	CCV6000-08L	Filter Unit
	1	CCV6000-08R	Filter Unit
	2	CCV55046	Fitting/Hose Kit
	2	AF M601212	Marine Air Filter
KTA50, KTTA50 (Continuous Duty Engines)	1	CCV8000-08L	Filter Unit
	1	CCV8000-08R	Filter Unit
	2	CCV55067	Fitting/Hose Kit
	2	CCV60125	Tap sleeves
	or		
	2	AF M601212	Marine Air Filter

CCV Engine Applications

Detroit Diesel - Industrial/Mobile Power Applications

ENGINE MODEL NO.	QTY.	P/N	DESCRIPTION
3-53, 4-53, 3-71*, Series 50	1	CCV4500-08L (or R)	Filter Unit
	1	CCV55037	Fitting/Hose Kit
	1	CCV40100	Tap Sleeve
8.2 Liter	1	CCV4500-08L (or R)	Filter Unit
	1	CCV55038	Fitting/Hose Kit
	1	CCV40100	Tap Sleeve
4-71, 6-71, 6V71, 8V71*, 6V92, 6V53, 8V92 up to 20 CFM	1	CCV6000-08L (or R)	Filter Unit
	1	CCV55047	Fitting/Hose Kit
	1	CCV50125	Tap Sleeve
Series 60/ 11.2, 12.7 Liter	1	CCV6000-08L (or R)	Filter Unit
	1	CCV55046	Fitting/Hose Kit
	1	CCV50125	Tap Sleeve
8V92, 12V71*	1	CCV6000-08L	Filter Unit
	1	CCV6000-08R	Filter Unit
	2	CCV55046	Fitting/Hose Kit
	2	CCV50125	Tap Sleeve
12V92, 16V92	1	CCV6000-08L	Filter Unit
	1	CCV6000-08R	Filter Unit
	2	CCV55047	Fitting/Hose Kit
	2	CCV50125	Tap Sleeve
12V149, 16V149 with 3 rocker cover breathers	1	CCV8000-08L	Filter Unit
	1	CCV8000-08R	Filter Unit
	1	CCV55067	Fitting/Hose Kit
	1	CCV55068	Fitting/Hose Kit
	2	CCV60125	Tap Sleeve
16V149, 20V149 High h/p engines with 4 rocker cover breathers	1	CCV8000-08L	Filter Unit
	1	CCV8000-08R	Filter Unit
	2	CCV55068	Fitting/Hose Kit
	2	CCV60125	Tap Sleeve

*In all applications, please verify turbo inlet outside diameter size for correct application of tap sleeve.

Detroit Diesel - Marine Applications

ENGINE MODEL NO.	QTY.	P/N	DESCRIPTION
3-53, 4-53, 3-71*, Series 50	1	CCV4500-08L (or R)	Filter Unit
	1	CCV55037	Fitting/Hose Kit
	1	AF M408512	Marine Air Filter
3.2 Liter	1	CCV4500-08L (or R)	Filter Unit
	1	CCV55038	Fitting/Hose Kit
	1	AF M408512	Marine Air Filter
4-71, 6-71, 6V71, 8V71*, 6V92, 6V53, 8V92 up to 600 hp (single turbo)	1	CCV6000-08L (or R)	Filter Unit
	1	CCV55047	Fitting/Hose Kit
	1	AF M601212	Marine Air Filter
	* twin turbo use (2) AF M501012, Marine Air Filters		
Series 60/ 11.2, 12.7 Liter	1	CCV6000-08L (or R)	Filter Unit
	1	CCV55046	Fitting/Hose Kit
	1	AF M501012	Marine Air Filter
8V92, 12V71*	1	CCV6000-08L	Filter Unit
	1	CCV6000-08R	Filter Unit
	2	CCV55046	Fitting/Hose Kit
	2	AF M501012	Marine Air Filter
12V92, 16V92	1	CCV6000-08L	Filter Unit
	1	CCV6000-08R	Filter Unit
	2	CCV55047	Fitting/Hose Kit
	2	AF M601212	Marine Air Filter
12V149, 16V149 with 3 rocker cover breathers	1	CCV8000-08L	Filter Unit
	1	CCV8000-08R	Filter Unit
	1	CCV55067	Fitting/Hose Kit
	1	CCV55068	Fitting/Hose Kit
	2	AF M601212	Marine Air Filter
16V149, 20V149 High h/p engines with 4 rocker cover breathers	1	CCV8000-08L	Filter Unit
	1	CCV8000-08R	Filter Unit
	2	CCV55068	Fitting/Hose Kit
	4	AF M601212	Marine Air Filter

*In all applications, please verify turbo inlet outside diameter size for correct application of tap sleeve.

CCV Engine Applications

Hercules - Industrial/Mobile Power Applications

ENGINE MODEL NO.	QTY.	P/N	DESCRIPTION
G1600, 62300	1	CCV4500-08L (or R)	Filter Unit
	1	CCV55024	Fitting/Hose Kit
	1	CCV40100	Tap Sleeve
G3400, G4800, D2300 Series, D3400 Series, D4800 Series	1	CCV4500-08L (or R)	Filter Unit
	1	CCV55025	Fitting/Hose Kit
	1	CCV40100	Tap Sleeve

Volvo - Industrial/Mobile Power Applications

ENGINE MODEL NO.	QTY.	P/N	DESCRIPTION
All engine models with P/N 876069-0 breather cartridge	1	CCV4500-08L (or R)	Filter Unit
	1	CCV55037	Fitting/Hose Kit
	1	CCV40100	Tap Sleeve

Volvo - Marine Applications

ENGINE MODEL NO.	QTY.	P/N	DESCRIPTION
All engine models with P/N 876069-0 breather cartridge less than 400 hp	1	CCV4500-08L (or R)	Filter Unit
	1	CCV55037	Fitting/Hose Kit
	1	AF M408512	Marine Air Filter
All engine models with P/N 876069-0 breather cartridge over 400 hp	1	CCV6000-08L (or R)	Filter Unit
	1	CCV55046	Fitting/Hose Kit
	1	AF M501012	Marine Air Filter

John Deere - Industrial/Mobile Power Applications

ENGINE MODEL NO.	QTY.	P/N	DESCRIPTION
<i>Series 300/400, 4039T, 4045T, 6059T, 6059D, 6359A, 6068D, 6068T, 6076T, 6076A, 6076H</i>	1	CCV4500-08R	Filter Unit
	1	CCV55024	Fitting/Hose Kit
	1	CCV40100	Tap Sleeve
<i>Series 500, 6619A</i>	1	CCV4500-08R	Filter Unit
	1	CCV55025	Fitting/Hose Kit
	1	CCV40100	Tap Sleeve

John Deere - Marine Applications

ENGINE MODEL NO.	QTY.	P/N	DESCRIPTION
<i>Series 300/400, 4039T, 4045T, 6059T, 6059D, 6359A, 6068D, 6068T, 6076T, 6076A, 6076H</i>	1	CCV4500-08R	Filter Unit
	1	CCV55024	Fitting/Hose Kit
	1	AF M408512	Marine Air Filter
<i>Series 500, 6619A</i>	1	CCV4500-08R	Filter Unit
	1	CCV55045	Fitting/Hose Kit
	1	AF M408512	Marine Air Filter

Mack - Industrial/Mobile Power Applications

ENGINE MODEL NO.	QTY.	P/N	DESCRIPTION
<i>E6, E7, 37G, E9</i>	1	CCV6000-08L (or R)	Filter Unit
	1	CCV55048	Fitting/Hose Kit
	1	CCV50125	Tap Sleeve

Mack - Marine Applications

ENGINE MODEL NO.	QTY.	P/N	DESCRIPTION
<i>E6, E7, 37G, E9 (up to 600 hp)</i>	1	CCV6000-08L (or R)	Filter Unit
	1	CCV55048	Fitting/Hose Kit
	1	AF M501012 (Note: over 600 hp use AF M601212)	Marine Air Filter
<i>E6, E7, 37G, E9 (over 700 hp)</i>	1	CCV8000-08L (or R)	Filter Unit
	1	CCV55067	Fitting/Hose Kit
	1	AF M601212	Marine Air Filter

Limited Warranties Statement

All products manufactured or distributed by Racor are subject to the following, and only the following, LIMITED EXPRESS WARRANTIES, and no others: For a period of one (1) year from and after the date of purchase of a new Racor product, Racor warrants and guarantees only to the original purchaser-user that such a product shall be free from defects of materials and workmanship in the manufacturing process. The warranty period for pumps and motors is specifically limited to ninety (90) days from date of purchase. A product claimed to be defective must be returned to the place of purchase. Racor, at its sole option, shall replace the defective product with a comparable new product or repair the defective product. This express warranty shall be inapplicable to any product not properly installed and properly used by the purchaser-user or to any product damaged or impaired by external forces.

THIS IS THE EXTENT OF WARRANTIES AVAILABLE ON THIS PRODUCT. RACOR SHALL HAVE NO LIABILITY WHATSOEVER FOR CONSEQUENTIAL DAMAGES

FLOWING FROM THE USE OF ANY DEFECTIVE PRODUCT OR BY REASON OF THE FAILURE OF ANY PRODUCT. RACOR SPECIFICALLY DISAVOWS ALL OTHER WARRANTIES, EXPRESS OR IMPLIED INCLUDING, WITHOUT LIMITATION, ALL WARRANTIES OF FITNESS FOR A PARTICULAR PURPOSE (EXCEPT FOR THOSE WHICH APPLY TO PRODUCT OR PART THEREOF THAT IS USED OR BOUGHT FOR USE PRIMARILY FOR PERSONAL, FAMILY, OR HOUSEHOLD PURPOSES), WARRANTIES OF DESCRIPTION, WARRANTIES OF MERCHANTABILITY, TRADE USAGE OR WARRANTIES OR TRADE USAGE.

Warning

Failure or improper selection or improper use of the products and/or systems described herein or related items can cause death, personal injury and property damage. This document and other information from Parker Hannifin Corporation, its subsidiaries and authorized distributors provide product

and/or system options for further investigation by users having technical expertise. It is important that you analyze all aspects of your application and review the information concerning the product or system in the current product catalog. Due to the variety of operating conditions and applications for these products or systems, the user, through its own analysis and testing, is solely responsible for making the final selection of the products and systems and assuring that all performance, safety and warning requirements of the applications are met. The products described herein, including with limitation, product features, specifications, designs, availability and pricing, are subject to change by Parker Hannifin Corporation and its subsidiaries at any time without notice.

The following statement is required pursuant to proposition 65, applicable in the State of California: 'This product may contain a chemical known to the State of California to cause cancer or reproductive toxicity.'